

PLA100F

PL A 100 F -□ -□
 ① ② ③ ④ ⑤ ⑥

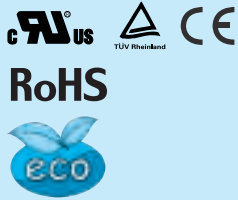

Recommended EMI/EMC Filter
NAC-04-472



High voltage pulse noise type : NAP series
 Low leakage current type : NAM series
 *The EMI/EMC Filter is recommended to connect with several devices.

- ① Series name
- ② Single output
- ③ Output wattage
- ④ Universal input
- ⑤ Output voltage
- ⑥ Optional *7
- C : with Coating
- R : Remote on/off (Required external power source)
- J : Connector interface
- T : Vertical terminal block
- L : Lower power consumption (0.5W max at AC240Vin, no load, ErP-compliant)
- N1: with DIN rail

Refer to instruction manual 5.1 about optional.

SPECIFICATIONS

* Please consider "PBA100F-5-N" about 5V output with case cover.

MODEL		PLA100F-12	PLA100F-15	PLA100F-24	PLA100F-36	PLA100F-48
VOLTAGE[V]		AC85 - 264 1 φ (Output derating is required at AC85V - 115V. Refer to instruction manual 1.1 and 3.2) (DC input *3)				
CURRENT[A]	ACIN 100V	1.2typ (Io=90%)				
	ACIN 115V	1.1typ (Io=100%)				
	ACIN 230V	0.6yp (Io=100%)				
FREQUENCY[Hz]		50 / 60 (47 - 63) (DC input and 440Hz *3)				
EFFICIENCY[%]	ACIN 100V	82typ (Io=90%)	83typ (Io=90%)	85typ (Io=90%)	86typ (Io=90%)	86typ (Io=90%)
	ACIN 115V	82typ (Io=100%)	83typ (Io=100%)	85typ (Io=100%)	86typ (Io=100%)	86typ (Io=100%)
	ACIN 230V	85typ (Io=100%)	86typ (Io=100%)	88typ (Io=100%)	89typ (Io=100%)	89typ (Io=100%)
POWER FACTOR	ACIN 100V	0.98typ (Io=90%)				
	ACIN 115V	0.98typ (Io=100%)				
	ACIN 230V	0.95typ (Io=100%) * Power factor correction is stopped at AC250V or more.				
INRUSH CURRENT[A]	ACIN 100V	16typ (Io=90%) Ta=25°C at cold start				
	ACIN 115V	16typ (Io=100%) Ta=25°C at cold start				
	ACIN 230V	32typ (Io=100%) Ta=25°C at cold start				
LEAKAGE CURRENT[mA]		0.75max (ACIN 115V / 240V, 60Hz, Io=100%, According to IEC60950-1 and DEN-AN)				
VOLTAGE[V]		12	15	24	36	48
CURRENT[A]	ACIN 85-115V	Output derating is required at ACIN 115V or less (refer to instruction manual 3.2)				
	ACIN 115V-264V	8.4	6.7	4.3	2.8	2.1
WATTAGE[W]	ACIN 85-115V	Output derating is required at ACIN 115V or less (refer to instruction manual 3.2)				
	ACIN 115V-264V	100.8	100.5	103.2	100.8	100.8
LINE REGULATION[mV] *4		48max	60max	96max	144max	192max
LOAD REGULATION [mV] *4	Io=30 to 100%	100max	120max	150max	150max	300max
	Io=0 to 30%	Burst operation (Please contact us about detail)				
RIPPLE[mVp-p] *1	0 to +40°C	120max	120max	120max	150max	150max
	-10 to 0°C	160max	160max	160max	200max	400max
	Io: load factor	Io=0 to 30%	500max	500max	500max	500max
RIPPLE NOISE[mVp-p] *1	0 to +40°C	150max	150max	150max	200max	200max
	-10 to 0°C	180max	180max	180max	240max	500max
	Io: load factor	Io=0 to 30%	600max	600max	600max	600max
TEMPERATURE REGULATION[mV]	0 to +40°C	120max	150max	240max	360max	480max
	-10 to +40°C	180max	180max	290max	440max	600max
DRIFT[mV] *2		48max	60max	96max	144max	192max
START-UP TIME[ms]		500typ (ACIN 115V, Io=100%) Ta=25°C				
HOLD-UP TIME[ms]		20typ (ACIN 115V, Io=100%)				
OUTPUT VOLTAGE ADJUSTMENT RANGE[V]		10.80 to 13.20	13.50 to 16.50	21.60 to 26.40	32.40 to 39.60	43.20 to 52.80
OUTPUT VOLTAGE SETTING[V]		12.00 to 12.48	15.00 to 15.60	24.00 to 24.96	36.00 to 37.44	48.00 to 49.92
OVERCURRENT PROTECTION		Works over 105% of rating and recovers automatically				
OVERVOLTAGE PROTECTION[V]		13.80 to 16.80	17.25 to 21.00	27.60 to 33.60	41.40 to 50.40	54.00 to 67.20
OPERATING INDICATION		LED (Green)				
REMOTE SENSING		Not provided				
REMOTE ON/OFF		Optional (Required external power source. Option -R)				
ISOLATION	INPUT-OUTPUT • RC *9	AC3,000V 1minute, Cutoff current = 10mA, DC500V 50MΩ min (At room temperature)				
	INPUT-FG	AC2,000V 1minute, Cutoff current = 10mA, DC500V 50MΩ min (At room temperature)				
	OUTPUT • RC-FG *9	AC500V 1minute, Cutoff current = 100mA, DC500V 50MΩ min (At room temperature)				
	OUTPUT-RC *9	AC500V 1minute, Cutoff current = 100mA, DC500V 50MΩ min (At room temperature)				
ENVIRONMENT	OPERATING TEMP., HUMID. AND ALTITUDE *5	-20 to +70°C (Output derating is required), 20 - 90%RH (Non condensing), 3,000m (10,000 feet) max				
	STORAGE TEMP., HUMID. AND ALTITUDE	-20 to +75°C, 20 - 90%RH (Non condensing), 9,000m (30,000 feet) max				
	VIBRATION	10 - 55Hz, 19.6m/s ² (2G), 3minutes period, 60minutes each along X, Y and Z axes				
	IMPACT	196.1m/s ² (20G), 11ms, once each X, Y and Z axes				
SAFETY AND NOISE REGULATIONS	AGENCY APPROVALS	UL60950-1, C-UL (CSA60950-1), EN60950-1, EN50178, UL508 (Except option -J) Complies with DEN-AN				
	CONDUCTED NOISE	Complies with FCC-B, VCCI-B, CISPR22-B, EN55011-B, EN55022-B				
	HARMONIC ATTENUATOR *8	Complies with IEC61000-3-2 class A				

SPECIFICATIONS

OTHERS	CASE SIZE/WEIGHT	41 × 97 × 109mm [1.61 × 3.82 × 4.29 inches] (Excluding terminal block and screw) (W × H × D) / 500g max
	COOLING METHOD	Convection
WARRANTY	WARRANTY	*6 5-year (Depends on the used condition)

- *1 This is the value that measured on measuring board with capacitor of 22 μF and 0.1 μF at 150mm from output terminal. Measured by 20MHz oscilloscope or Ripple-Noise meter (Equivalent to KEISOKU-GIKEN: RM103). Please refer to the instruction manual 1.6. Ripple and ripple noise spec is change at Io=0 ~ 30% by low power mode.
- *2 Drift is the change in DC output for an eight hour period after a half-hour warm-up at 25°C.
- *3 Derating is required. As for DC input, please contact us.
- *4 Please contact us about dynamic load and input response. Also, please measure output voltage in average mode because of burst operation at 30% load or less.
- *5 Derating is required. Please refer to instruction manual 3.2.
- *6 As for detail condition, please refer to instruction manual 3.3.
- *7 Please contact us about safety approvals for the model with option.
- *8 Please contact us about other class.
- *9 RC terminal is applied at option -R. And RC terminal is isolated from input, output and FG.
- * To meet the specifications, do not operate over-loaded condition.
- * Parallel operation is not possible.
- * A sound may occur from power supply at peak loading.

Features

- Compact design (Depth: 109mm 4.29inches)
- High efficiency (88%typ PLA100F-24, AC230Vin, 100% load)
- Low power consumption (1.5W typ AC240Vin, no load at standard model)
- Lower power consumption (0.5Wmax AC240Vin, no load at option -L: refer to instruction manual)
- UL508 approved (Except option -J), and complies with SEMI F47 (Refer to instruction manual 1.1)
- Various option (Optional connectors : Vertical terminal block, Connector wiring)

Block diagram

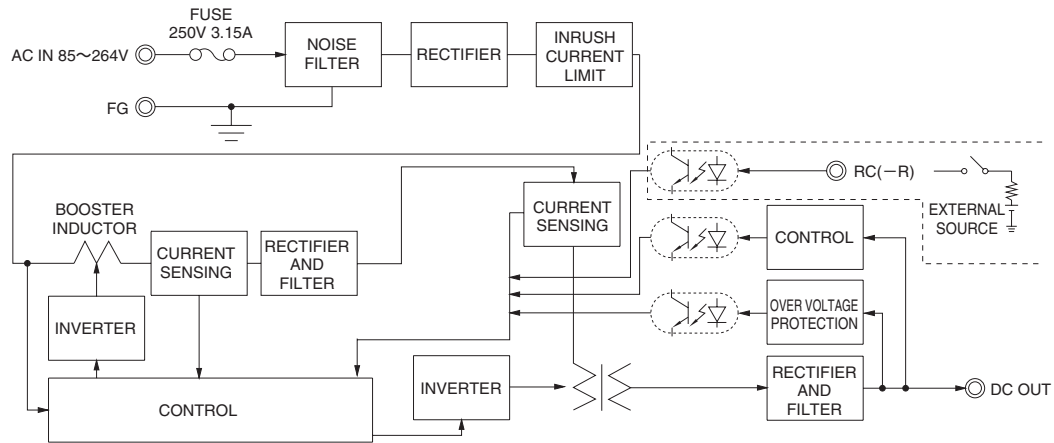

External view

External size of option R, J, N1 and T is different from standard model, and refer to "5 Option and others" of instruction manual for detail.

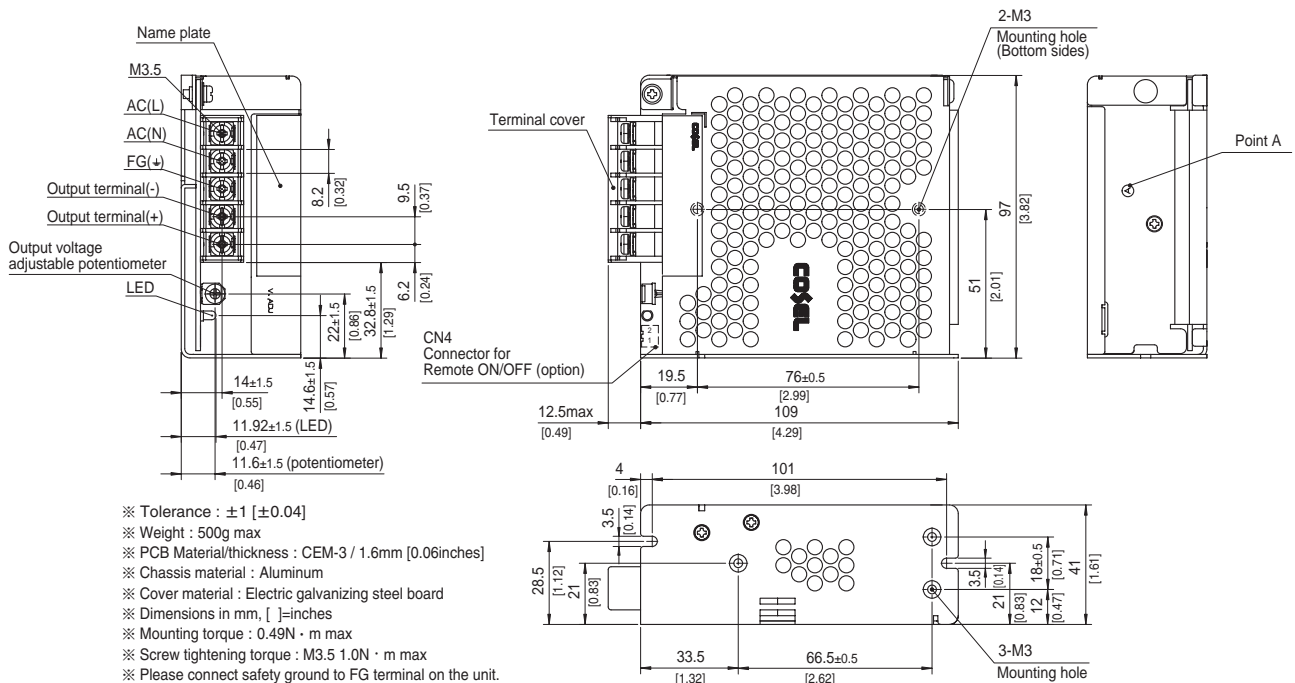

PLA150F

① PL ② A ③ 150 ④ F ⑤ -□ ⑥ -□

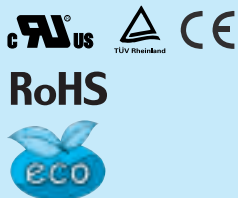

Recommended EMI/EMC Filter
NAC-04-472

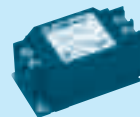

High voltage pulse noise type : NAP series
Low leakage current type : NAM series
*The EMI/EMC Filter is recommended to connect with several devices.

- ① Series name
- ② Single output
- ③ Output wattage
- ④ Universal input
- ⑤ Output voltage
- ⑥ Optional *7
- C : with Coating
- R : Remote on/off (Required external power source)
- J : Connector interface
- T : Vertical terminal block
- L : Lower power consumption (0.5W max at AC240Vin, no load, ErP-compliant)
- N1: with DIN rail

Refer to instruction manual 5.1 about optional.

SPECIFICATIONS

* Please consider "PBA150F-5-N" about 5V output with case cover.

MODEL		PLA150F-12	PLA150F-15	PLA150F-24	PLA150F-36	PLA150F-48	
INPUT	VOLTAGE[V]	AC85 - 264 1 φ (Output derating is required at AC85V - 115V. Refer to instruction manual 1.1 and 3.2) (DC input *3)					
	CURRENT[A]	ACIN 100V	1.7typ (Io=90%)				
		ACIN 115V	1.6typ (Io=100%)				
		ACIN 230V	0.8typ (Io=100%)				
	FREQUENCY[Hz]	50 / 60 (47 - 63) (DC input and 440Hz *3)					
	EFFICIENCY[%]	ACIN 100V	84typ (Io=90%)	84typ (Io=90%)	87typ (Io=90%)	87typ (Io=90%)	87typ (Io=90%)
		ACIN 115V	84typ (Io=100%)	84typ (Io=100%)	87typ (Io=100%)	87typ (Io=100%)	87typ (Io=100%)
		ACIN 230V	87typ (Io=100%)	87typ (Io=100%)	90typ (Io=100%)	90typ (Io=100%)	90typ (Io=100%)
	POWER FACTOR	ACIN 100V	0.98typ (Io=90%)				
		ACIN 115V	0.98typ (Io=100%)				
ACIN 230V		0.95typ (Io=100%) * Power factor correction is stopped at AC250V or more.					
INRUSH CURRENT[A]	ACIN 100V	16typ (Io=90%) Ta=25°C at cold start					
	ACIN 115V	16typ (Io=100%) Ta=25°C at cold start					
	ACIN 230V	32typ (Io=100%) Ta=25°C at cold start					
LEAKAGE CURRENT[mA]	0.75max (ACIN 115V / 240V, 60Hz, Io=100%, According to IEC60950-1 and DEN-AN)						
OUTPUT	VOLTAGE[V]	12	15	24	36	48	
	CURRENT[A]	ACIN 85-115V	Output derating is required at ACIN 115V or less (refer to instruction manual 3.2)				
		ACIN 115V-264V	12.5	10	6.4	4.2	3.2
	WATTAGE[W]	ACIN 85-115V	Output derating is required at ACIN 115V or less (refer to instruction manual 3.2)				
		ACIN 115V-264V	150.0	150.0	153.6	151.2	153.6
	LINE REGULATION[mV]	*4	48max	60max	96max	144max	192max
	LOAD REGULATION [mV]	Io=30 to 100%	100max	120max	150max	150max	300max
		Io=0 to 30%	Burst operation (Please contact us about detail)				
	RIPPLE[mVp-p]	0 to +40°C	120max	120max	120max	150max	150max
		-10 to 0°C	160max	160max	160max	200max	400max
		Io: load factor	Io=0 to 30%	500max	500max	500max	500max
	RIPPLE NOISE[mVp-p]	0 to +40°C	150max	150max	150max	200max	200max
		-10 to 0°C	180max	180max	180max	240max	500max
		Io: load factor	Io=0 to 30%	600max	600max	600max	600max
	TEMPERATURE REGULATION[mV]	0 to +40°C	120max	150max	240max	360max	480max
-10 to +40°C		180max	180max	290max	440max	600max	
DRIFT[mV]	*2	48max	60max	96max	144max	192max	
START-UP TIME[ms]	500typ (ACIN 115V, Io=100%) Ta=25°C						
HOLD-UP TIME[ms]	20typ (ACIN 115V, Io=100%)						
OUTPUT VOLTAGE ADJUSTMENT RANGE[V]	10.80 to 13.20		13.50 to 16.50		21.60 to 26.40		
OUTPUT VOLTAGE SETTING[V]	12.00 to 12.48		15.00 to 15.60		24.00 to 24.96		
OVERCURRENT PROTECTION	Works over 105% of rating and recovers automatically						
OVERVOLTAGE PROTECTION[V]	13.80 to 16.80		17.25 to 21.00		27.60 to 33.60		
OPERATING INDICATION	LED (Green)						
REMOTE SENSING	Not provided						
REMOTE ON/OFF	Optional (Required external power source. Option -R)						
ISOLATION	INPUT-OUTPUT • RC	*9 AC3,000V 1minute, Cutoff current = 10mA, DC500V 50MΩ min (At room temperature)					
	INPUT-FG	AC2,000V 1minute, Cutoff current = 10mA, DC500V 50MΩ min (At room temperature)					
	OUTPUT • RC-FG	*9 AC500V 1minute, Cutoff current = 100mA, DC500V 50MΩ min (At room temperature)					
	OUTPUT-RC	*9 AC500V 1minute, Cutoff current = 100mA, DC500V 50MΩ min (At room temperature)					
ENVIRONMENT	OPERATING TEMP., HUMID. AND ALTITUDE *5	-20 to +70°C (Output derating is required), 20 - 90%RH (Non condensing), 3,000m (10,000 feet) max					
	STORAGE TEMP., HUMID. AND ALTITUDE	-20 to +75°C, 20 - 90%RH (Non condensing), 9,000m (30,000 feet) max					
	VIBRATION	10 - 55Hz, 19.6m/s ² (2G), 3minutes period, 60minutes each along X, Y and Z axes					
	IMPACT	196.1m/s ² (20G), 11ms, once each X, Y and Z axes					
SAFETY AND NOISE REGULATIONS	AGENCY APPROVALS	UL60950-1, C-UL (CSA60950-1), EN60950-1, EN50178, UL508 (Except option -J) Complies with DEN-AN					
	CONDUCTED NOISE	Complies with FCC-B, VCCI-B, CISPR22-B, EN55011-B, EN55022-B					
	HARMONIC ATTENUATOR *8	Complies with IEC61000-3-2 class A					

SPECIFICATIONS

OTHERS	CASE SIZE/WEIGHT	41 × 97 × 129mm [1.61 × 3.82 × 5.08 inches] (Excluding terminal block and screw) (W × H × D) / 600g max
	COOLING METHOD	Convection
WARRANTY	WARRANTY	*6 5-year (Depends on the used condition)

- *1 This is the value that measured on measuring board with capacitor of 22 μF and 0.1 μF at 150mm from output terminal. Measured by 20MHz oscilloscope or Ripple-Noise meter (Equivalent to KEISOKU-GIKEN: RM103). Please refer to the instruction manual 1.6. Ripple and ripple noise spec is change at Io=0 ~ 30% by low power mode.
- *2 Drift is the change in DC output for an eight hour period after a half-hour warm-up at 25°C.

- *3 Derating is required. As for DC input, please contact us.
- *4 Please contact us about dynamic load and input response. Also, please measure output voltage in average mode because of burst operation at 30% load or less.
- *5 Derating is required. Please refer to instruction manual 3.2.
- *6 As for detail condition, please refer to instruction manual 3.3.
- *7 Please contact us about safety approvals for the model with option.
- *8 Please contact us about other class.

- *9 RC terminal is applied at option -R. And RC terminal is isolated from input, output and FG.
- * To meet the specifications, do not operate over-loaded condition.
- * Parallel operation is not possible.
- * A sound may occur from power supply at peak loading.

Features

- Compact design (Depth: 129mm 5.08inches)
- High efficiency (90%typ PLA150F-24, AC230Vin, 100% load)
- Low power consumption (1.5W typ AC240Vin, no load at standard model)
- Lower power consumption (0.5Wmax AC240Vin, no load at option -L: refer to instruction manual)
- UL508 approved (Except option -J), and complies with SEMI F47 (Refer to instruction manual 1.1)
- Various option (Optional connectors : Vertical terminal block, Connector wiring)

Block diagram

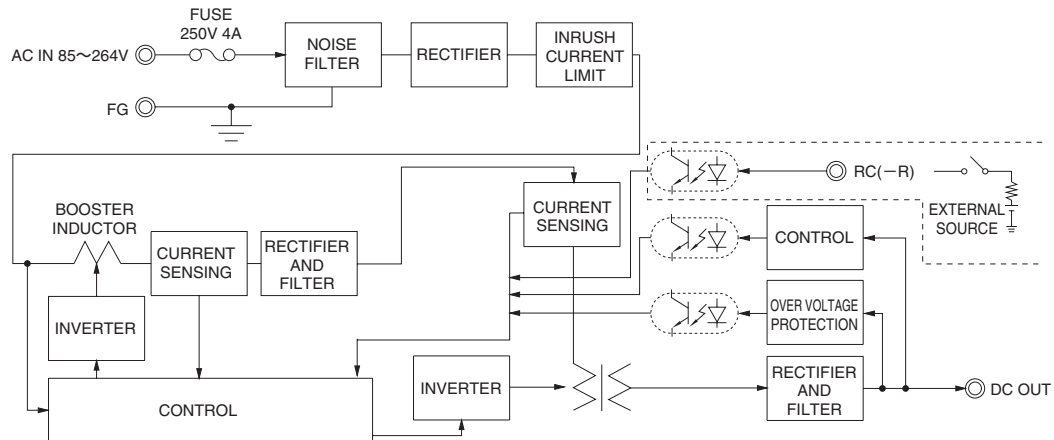

External view

External size of option R, J, N1 and T is different from standard model, and refer to "5 Option and others" of instruction manual for detail.

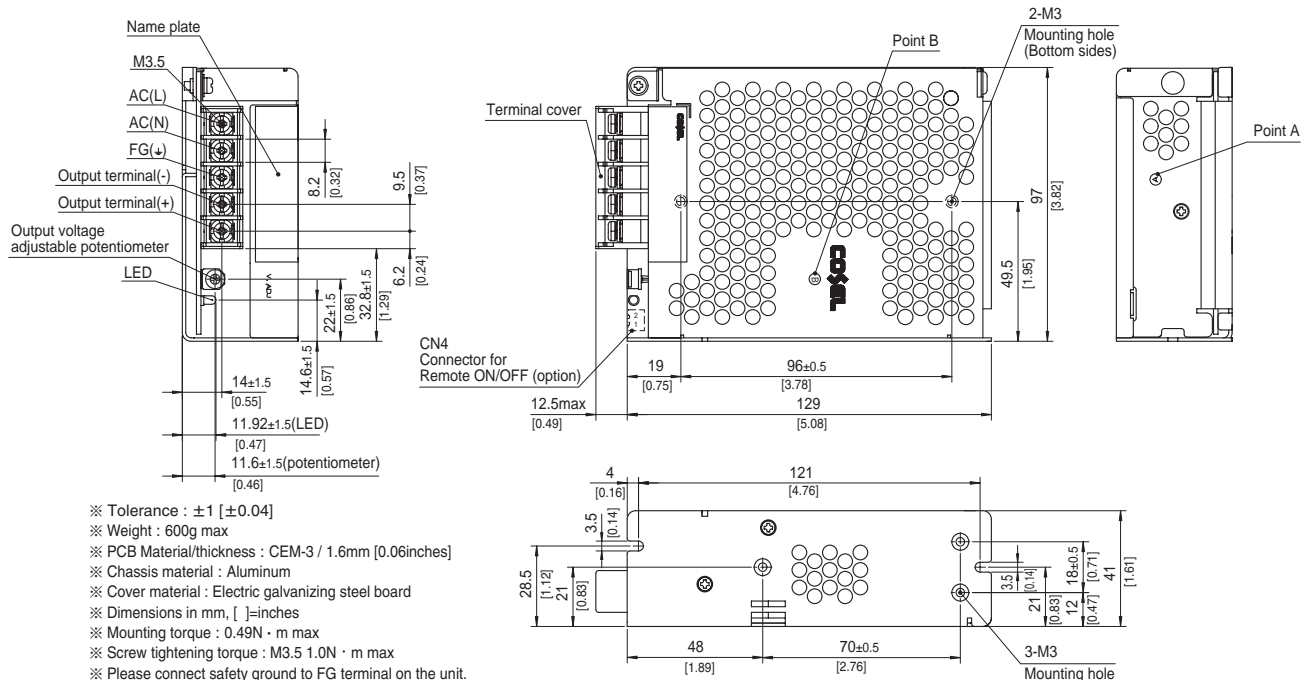

PLA300F

PL A 300 F -□ -□
 ① ② ③ ④ ⑤ ⑥



Recommended EMI/EMC Filter
NAC-06-472

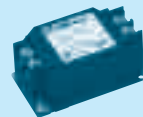

High voltage pulse noise type : NAP series
 Low leakage current type : NAM series
 *The EMI/EMC Filter is recommended to connect with several devices.

- ① Series name
- ② Single output
- ③ Output wattage
- ④ Universal input
- ⑤ Output voltage
- ⑥ Optional *7
- C : with Coating
- G : Low leakage current
- V : External potentiometer for output voltage adjustment
- U : Low input voltage stop (Complies with SEMI F-47)
- R : Remote on/off (Required external power source)
- F4: Low speed fan
- T2: Horizontal terminal block (Not screw hold type)

Refer to instruction manual 5.1 about optional.

SPECIFICATIONS

	MODEL	PLA300F-5	PLA300F-12	PLA300F-15	PLA300F-24	PLA300F-36	PLA300F-48		
INPUT	VOLTAGE[V]	AC85 - 264 1 φ (Output derating is required at AC85V - 115V. Refer to instruction manual 1.1 and 3.2) *3 (DC input and AC265 - 277V input *3)							
	CURRENT[A]	ACIN 100V	3.1typ (Io=90%)	3.4typ (Io=90%)					
		ACIN 115V	3.0typ (Io=100%)	3.3typ (Io=100%)					
		ACIN 230V	1.5typ (Io=100%)	1.7typ (Io=100%)					
	FREQUENCY[Hz]	50 / 60 (47 - 63) (DC input and 440Hz *3)							
	EFFICIENCY[%]	ACIN 100V	73typ (Io=90%)	78typ (Io=90%)	80typ (Io=90%)	84typ (Io=90%)	84typ (Io=90%)	84typ (Io=90%)	
		ACIN 115V	74typ (Io=100%)	78typ (Io=100%)	80typ (Io=100%)	84typ (Io=100%)	84typ (Io=100%)	84typ (Io=100%)	
		ACIN 230V	77typ (Io=100%)	81typ (Io=100%)	83typ (Io=100%)	87typ (Io=100%)	87typ (Io=100%)	87typ (Io=100%)	
	POWER FACTOR	ACIN 100V	0.98typ (Io=90%)						
		ACIN 115V	0.98typ (Io=100%)						
ACIN 230V		0.95typ (Io=100%)							
INRUSH CURRENT[A]	ACIN 100V	20typ (Io=90%) Ta=25°C at cold start							
	ACIN 115V	20typ (Io=100%) Ta=25°C at cold start							
	ACIN 230V	40typ (Io=100%) Ta=25°C at cold start							
LEAKAGE CURRENT[ma]	0.75max (ACIN 115V / 240V, 60Hz, Io=100%, According to IEC60950-1 and DEN-AN)								
OUTPUT	VOLTAGE[V]	5	12	15	24	36	48		
	CURRENT[A]	ACIN 85-115V	Output derating is required at ACIN 115V or less (refer to instruction manual 3.2)						
		ACIN 115V-264V	50	25	20	12.5	8.4	6.3	
	WATTAGE[W]	ACIN 85-115V	Output derating is required at ACIN 115V or less (refer to instruction manual 3.2)						
		ACIN 115V-264V	250	300	300	300	302.4	302.4	
	LINE REGULATION[mV]	*4	20max	48max	60max	96max	144max	192max	
	LOAD REGULATION[mV]	*4	40max	100max	120max	150max	150max	300max	
	RIPPLE[mVp-p]	*1	0 to +50°C	80max	120max	120max	120max	150max	150max
			-10 to 0°C	140max	160max	160max	160max	160max	400max
	RIPPLE NOISE[mVp-p]	*1	0 to +50°C	120max	150max	150max	150max	200max	200max
			-10 to 0°C	160max	180max	180max	180max	240max	500max
	TEMPERATURE REGULATION[mV]		0 to +50°C	50max	120max	150max	240max	360max	480max
			-10 to +50°C	75max	180max	180max	290max	440max	600max
	DRIFT[mV]	*2	20max	48max	60max	96max	144max	192max	
	START-UP TIME[ms]		300typ (ACIN 115V, Io=100%)						
HOLD-UP TIME[ms]		20typ (ACIN 115V, Io=100%)							
OUTPUT VOLTAGE ADJUSTMENT RANGE[V]		4.50 to 5.50	10.80 to 13.20	13.50 to 16.50	21.60 to 26.40	32.40 to 39.60	43.20 to 52.80		
OUTPUT VOLTAGE SETTING[V]		5.00 to 5.15	12.00 to 12.48	15.00 to 15.60	24.00 to 24.96	36.00 to 37.44	48.00 to 49.92		
PROTECTION CIRCUIT AND OTHERS	OVERCURRENT PROTECTION	Works over 105% of rating and recovers automatically							
	OVERVOLTAGE PROTECTION[V]	5.75 to 7.00	13.80 to 16.80	17.25 to 21.00	27.60 to 33.60	41.40 to 50.40	55.20 to 67.20		
	OPERATING INDICATION	LED (Green)							
	REMOTE SENSING	Not provided							
REMOTE ON/OFF	Optional (Required external power source. Option -R)								
ISOLATION	INPUT-OUTPUT · RC	*10	AC3,000V 1minute, Cutoff current = 10mA, DC500V 50MΩ min (At room temperature)						
	INPUT-FG		AC2,000V 1minute, Cutoff current = 10mA, DC500V 50MΩ min (At room temperature)						
	OUTPUT · RC-FG	*10	AC500V 1minute, Cutoff current = 100mA, DC500V 50MΩ min (At room temperature)						
	OUTPUT-RC	*10	AC500V 1minute, Cutoff current = 100mA, DC500V 50MΩ min (At room temperature)						
ENVIRONMENT	OPERATING TEMP., HUMID. AND ALTITUDE *5	-20 to +70°C (Output derating is required), 20 - 90%RH (Non condensing), 3,000m (10,000 feet) max							
	STORAGE TEMP., HUMID. AND ALTITUDE	-20 to +75°C, 20 - 90%RH (Non condensing), 9,000m (30,000 feet) max							
	VIBRATION	10 - 55Hz, 19.6m/s ² (2G), 3minutes period, 60minutes each along X, Y and Z axes							
	IMPACT	196.1m/s ² (20G), 11ms, once each X, Y and Z axes							
SAFETY AND NOISE REGULATIONS	AGENCY APPROVALS	UL60950-1, C-UL (CSA60950-1), EN60950-1, EN50178 Complies with DEN-AN							
	CONDUCTED NOISE	Complies with FCC-B, VCCI-B, CISPR22-B, EN55011-B, EN55022-B							
	HARMONIC ATTENUATOR *9	Complies with IEC61000-3-2 class A							

SPECIFICATIONS

OTHERS	CASE SIZE/WEIGHT	102×41×190mm [4.02×1.61×7.48 inches] (Excluding terminal block and screw) (W×H×D) / 1.0kg max
	COOLING METHOD	Forced cooling (internal fan)
WARRANTY	WARRANTY	*6 5-year (Depends on the used condition)

- *1 This is the value that measured on measuring board with capacitor of 22 μF and 0.1 μF at 150mm from output terminal. Measured by 20MHz oscilloscope or Ripple-Noise meter (Equivalent to KEISOKU-GIKEN: RM103). Please refer to the instruction manual 1.6.
- *2 Drift is the change in DC output for an eight hour period after a half-hour warm-up at 25°C.
- *3 Derating is required. As for DC input, 440Hz input and AC265 to 277V input, please contact us.
- *4 Please contact us about dynamic load and input response.
- *5 Derating is required. Please refer to instruction manual 3.2.
- *6 As for detail condition, please refer to instruction manual 3.3.
- *7 Please contact us about safety approvals for the model with option.
- *8 Fan speed is changed by load factor.
- *9 Please contact us about other class.
- *10 RC terminal is applied at option -R. And RC terminal is isolated from input, output and FG.
- * To meet the specifications, do not operate over-loaded condition.
- * Parallel operation is not possible.
- * A sound may occur from power supply at peak loading.

Features

- Economical model
- Long lifetime (Refer to instruction manual)
- Low profile (41mm, 1.61 inch = meet to 1U height)
- Wide temperature range (-20°C to +70°C Refer to instruction manual)
- Screw hold type terminal block
- Fan speed control (At no load condition)
- Various option
- Complies with SEMI F-47 (Option-U: Refer to instruction manual)

Block diagram

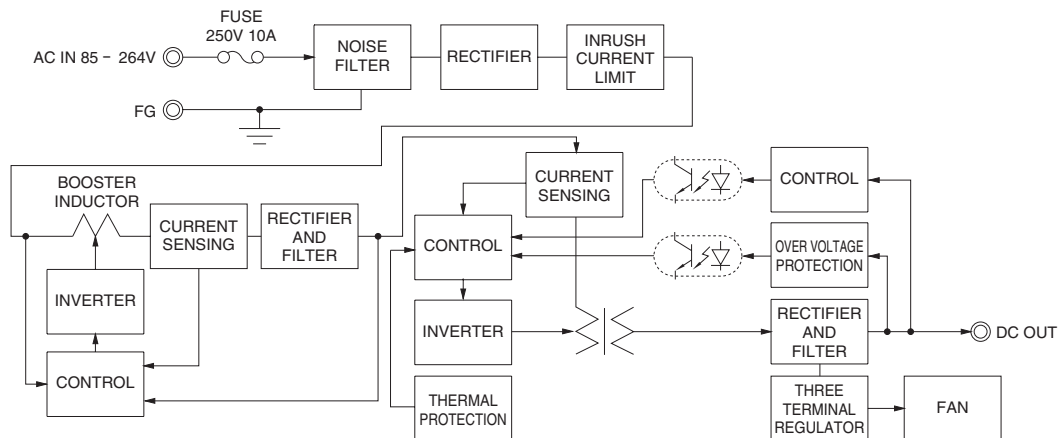

External view

External size of option V, option R and option T2 is different from standard model, and refer to "5. Option and Others" of instruction manual for detail.

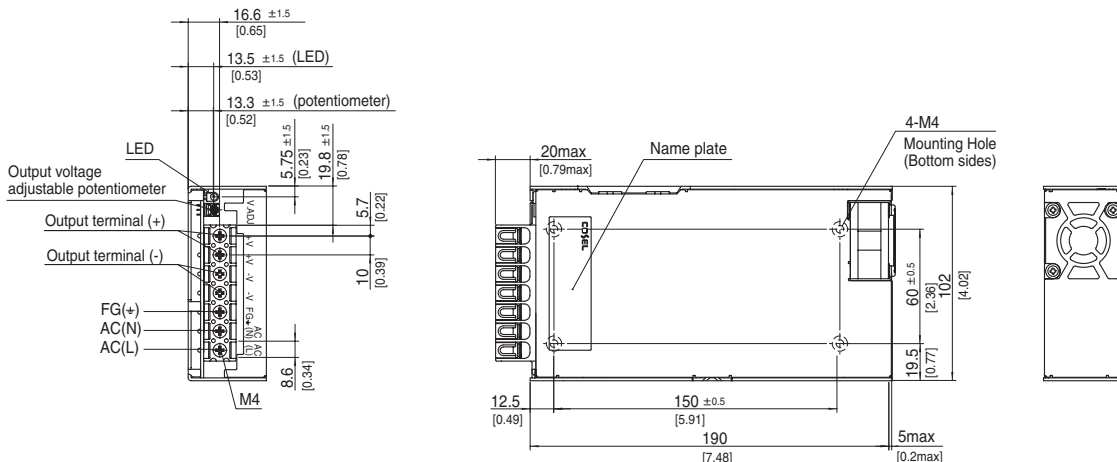

- ※ Tolerance : ±1 [±0.04]
- ※ Weight : 1.0kg max
- ※ PCB Material/thickness : CEM-3 / 1.6mm [0.06inches]
- ※ Chassis material : Aluminum
- ※ Case material : Electric galvanizing steel board
- ※ Dimensions in mm, []=inches
- ※ Mounting torque : 1.2N · m max
- ※ Screw tightening torque : 1.6N · m max
- ※ Please connect safety ground to FG terminal on the unit.

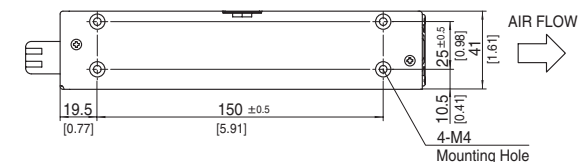

PLA600F

PL A 600 F -□ -□
 ① ② ③ ④ ⑤ ⑥

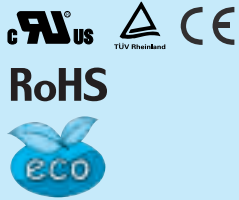

Recommended EMI/EMC Filter
NAC-16-472



High voltage pulse noise type : NAP series
 Low leakage current type : NAM series
 *The EMI/EMC Filter is recommended to connect with several devices.

- ① Series name
- ② Single output
- ③ Output wattage
- ④ Universal input
- ⑤ Output voltage
- ⑥ Optional *7
- C : with Coating
- G : Low leakage current
- V : External potentiometer for output voltage adjustment
- U : Low input voltage stop (Complies with SEMI F-47)
- W: Parallel operation, LV alarm Remote sensing
- R : Remote on/off (Required external power source)
- F4: Low speed fan
- T2: Horizontal terminal block (Not screw hold type)

Refer to instruction manual 5.1 about optional.

SPECIFICATIONS

MODEL		PLA600F-5	PLA600F-12	PLA600F-15	PLA600F-24	PLA600F-36	PLA600F-48	
INPUT	VOLTAGE[V]	AC85 - 264 1 φ (Output derating is required at AC85V - 115V. Refer to instruction manual 1.1 and 3.2) *4 (DC input and AC265 - 277V input *4)						
	CURRENT[A]	ACIN 100V	6.2typ (Io=90%)	6.7typ (Io=90%)				
		ACIN 115V	6.0typ (Io=100%)	6.5typ (Io=100%)				
		ACIN 230V	3.0typ (Io=100%)	3.2typ (Io=100%)				
	FREQUENCY[Hz]	50 / 60 (47 - 63) (DC input and 440Hz *4)						
	EFFICIENCY[%]	ACIN 100V	74typ (Io=90%)	81typ (Io=90%)	81typ (Io=90%)	84typ (Io=90%)	85typ (Io=90%)	85typ (Io=90%)
		ACIN 115V	75typ (Io=100%)	81typ (Io=100%)	81typ (Io=100%)	84typ (Io=100%)	85typ (Io=100%)	85typ (Io=100%)
		ACIN 230V	77typ (Io=100%)	84typ (Io=100%)	84typ (Io=100%)	88typ (Io=100%)	88typ (Io=100%)	88typ (Io=100%)
	POWER FACTOR	ACIN 100V	0.98typ (Io=90%)					
		ACIN 115V	0.98typ (Io=100%)					
ACIN 230V		0.95typ (Io=100%)						
INRUSH CURRENT[A]	ACIN 100V	20/40typ (Io=90%) (Primary inrush current /Secondary inrush current) (More than 3sec to re-start)						
	ACIN 115V	20/40typ (Io=100%) (Primary inrush current /Secondary inrush current) (More than 3sec to re-start)						
	ACIN 230V	40/40typ (Io=100%) (Primary inrush current /Secondary inrush current) (More than 3sec to re-start)						
LEAKAGE CURRENT[ma]	1.5max (ACIN 115V / 240V, 60Hz, Io=100%, According to IEC60950-1 and DEN-AN)							
OUTPUT	VOLTAGE[V]	5	12	15	24	36	48	
	CURRENT[A]	ACIN 85-115V	Output derating is required at ACIN 115V or less (refer to instruction manual 3.2)					
		ACIN 115V-264V	100	50	40	25	16.7	12.5
	WATTAGE[W]	ACIN 85-115V	Output derating is required at ACIN 115V or less (refer to instruction manual 3.2)					
		ACIN 115V-264V	500	600	600	600	601.2	600
	LINE REGULATION[mV] *8	20max	48max	60max	96max	144max	192max	
	LOAD REGULATION[mV] *8	40max	100max	120max	150max	150max	300max	
	RIPPLE[mVp-p] *1	0 to +50°C	80max	120max	120max	120max	150max	150max
		-20 to 0°C	140max	160max	160max	160max	160max	400max
	RIPPLE NOISE[mVp-p] *1	0 to +50°C	120max	150max	150max	150max	200max	200max
		-20 to 0°C	160max	180max	180max	180max	240max	500max
	TEMPERATURE REGULATION[mV]	0 to +50°C	50max	120max	150max	240max	360max	480max
		-20 to +50°C	75max	180max	180max	290max	440max	600max
	DRIFT[mV] *2	20max	48max	60max	96max	144max	192max	
	START-UP TIME[ms]	300typ (ACIN 115V, Io=100%)						
	HOLD-UP TIME[ms]	20typ (ACIN 115V, Io=100%)						
OUTPUT VOLTAGE ADJUSTMENT RANGE[V]	4.50 to 5.50	10.80 to 13.20	13.50 to 16.50	21.60 to 26.40	32.40 to 39.60	43.20 to 52.80		
OUTPUT VOLTAGE SETTING[V]	5.00 to 5.15	12.00 to 12.48	15.00 to 15.60	24.00 to 24.96	36.00 to 37.44	48.00 to 49.92		
PROTECTION CIRCUIT AND OTHERS	OVERCURRENT PROTECTION	Works over 105% of rating and recovers automatically						
	OVERVOLTAGE PROTECTION[V]	5.75 to 7.00	13.80 to 16.80	17.25 to 21.00	27.60 to 33.60	41.40 to 50.40	55.20 to 67.20	
	OPERATING INDICATION	LED (Green)						
	REMOTE SENSING	Optional (Option -W)						
REMOTE ON/OFF	Optional (Required external power source. Option -R)							
ISOLATION	INPUT-OUTPUT · RC *3	AC3,000V 1minute, Cutoff current = 10mA, DC500V 50MΩ min (At room temperature)						
	INPUT-FG	AC2,000V 1minute, Cutoff current = 10mA, DC500V 50MΩ min (At room temperature)						
	OUTPUT · RC-FG *3	AC500V 1minute, Cutoff current = 100mA, DC500V 50MΩ min (At room temperature)						
	OUTPUT-RC *3	AC500V 1minute, Cutoff current = 100mA, DC500V 50MΩ min (At room temperature)						
ENVIRONMENT	OPERATING TEMP., HUMID. AND ALTITUDE *5	-20 to +70°C (Output derating is required), 20 - 90%RH (Non condensing), 3,000m (10,000 feet) max						
	STORAGE TEMP., HUMID. AND ALTITUDE	-20 to +75°C, 20 - 90%RH (Non condensing), 9,000m (30,000 feet) max						
	VIBRATION	10 - 55Hz, 19.6m/s ² (2G), 3minutes period, 60minutes each along X, Y and Z axes						
	IMPACT	196.1m/s ² (20G), 11ms, once each X, Y and Z axes						
SAFETY AND NOISE REGULATIONS	AGENCY APPROVALS	UL60950-1, C-UL (CSA60950-1), EN60950-1, EN50178 Complies with DEN-AN						
	CONDUCTED NOISE	Complies with FCC-B, VCCI-B, CISPR22-B, EN55011-B, EN55022-B						
	HARMONIC ATTENUATOR *10	Complies with IEC61000-3-2 class A						

SPECIFICATIONS

OTHERS	CASE SIZE/WEIGHT	120×61×215mm [4.72×2.40×8.46 inches] (Excluding terminal block and screw) (W×H×D) / 2.0kg max
	COOLING METHOD	Forced cooling (internal fan)
WARRANTY	WARRANTY	*6 5-year (Depends on the used condition)

- *1 This is the value that measured on measuring board with capacitor of 22 μF and 0.1 μF at 150mm from output terminal. Measured by 20MHz oscilloscope or Ripple-Noise meter (Equivalent to KEISOKU-GIKEN: RM103). Please refer to the instruction manual 1.6.
- *2 Drift is the change in DC output for an eight hour period after a half-hour warm-up at 25°C.
- *3 RC terminal is applied at option -R. And RC terminal is isolated from input, output and FG.
- *4 Derating is required. As for DC input, 440Hz input and AC265 to 277V input, please contact us.
- *5 Derating is required. Please refer to instruction manual 3.2.
- *6 As for detail condition, please refer to instruction manual 3.3.
- *7 Please contact us about safety approvals for the model with option.
- *8 Please contact us about dynamic load and input response.
- *9 Fan speed is changed by load factor.
- *10 Please contact us about other class.
- * To meet the specifications, do not operate over-loaded condition.
- * Parallel operation with other model is not possible. In case of parallel operation with same model, please use option -W.
- * A sound may occur from power supply at peak loading.

Features

- Economical model
- Long lifetime (Refer to instruction manual)
- Low profile (61mm, 2.40 inch = meet to 2U height)
- Wide temperature range (-20°C to +70°C Refer to instruction manual)
- Screw hold type terminal block (Only input and FG terminal)
- Fan speed control (At no load condition)
- Various option
- Complies with SEMI F-47 (Option-U: Refer to instruction manual)

Block diagram

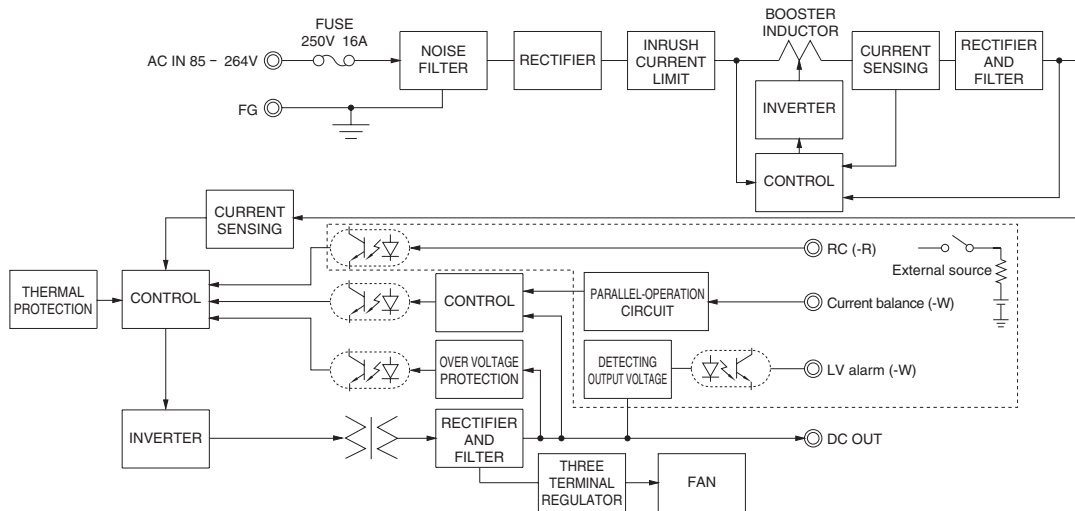

External view

External size of option V, option W, option R and option T2 are different from standard model, and refer to "5. Option and Others" of instruction manual for detail.

